

Dreipunkt Heckaushebung
Relevage triangulaire
Three point hitch

406-0

DHG

Art.No.

0646



Imprimé en Allemagne
Printed in Germany

B13

EB 1705.00

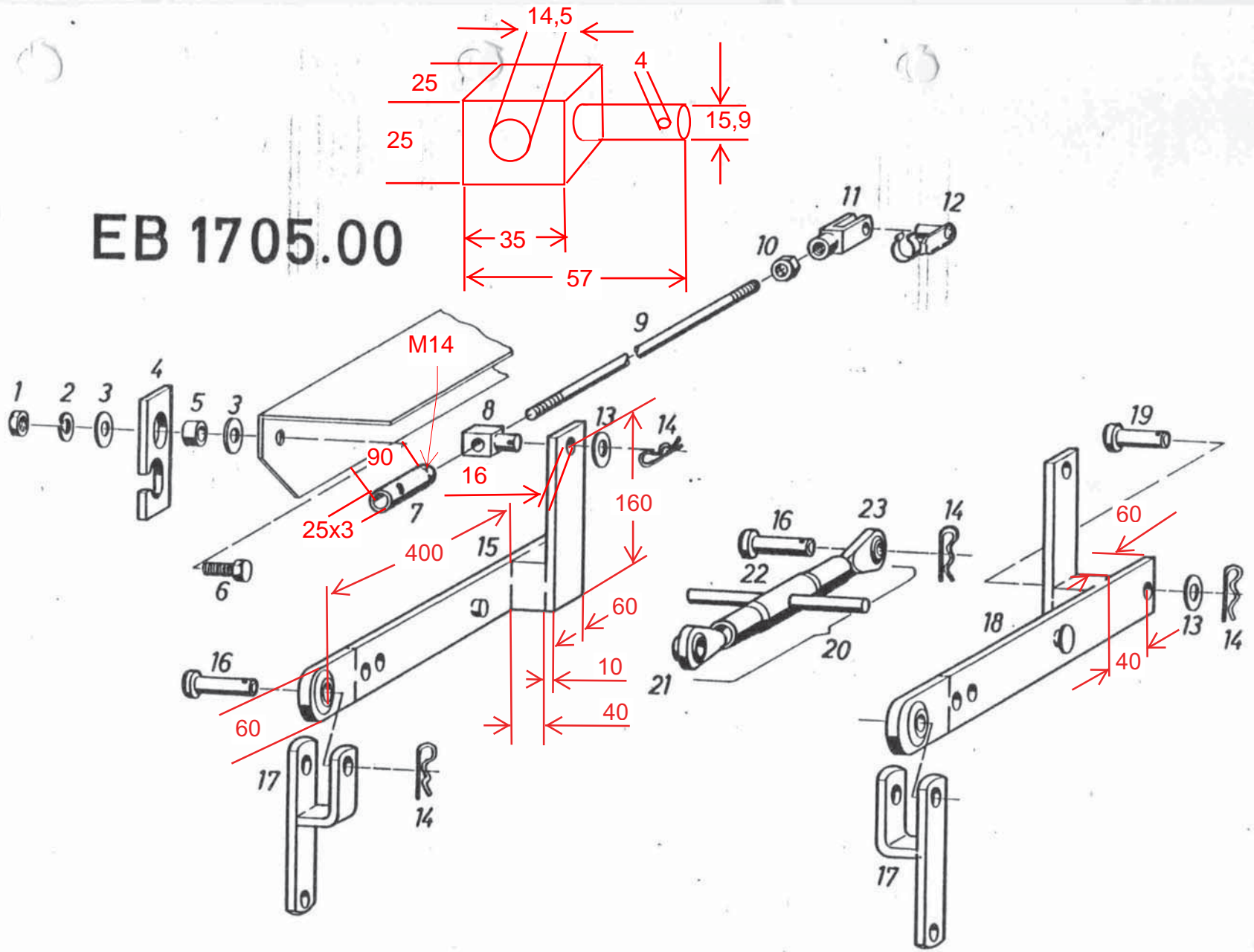

B 14

Fig. No.	Teile Nummer No. pièce Parts No.	Teile Bezeichnung	Désignation	Description	Norm-Bez. oder Fremdteile-Nr. No. de la norme ou référence fournisseur	Stück Nbr		
1	24.1421.25	Sechskantmutter	Ecrou	Nut	M 12 DIN 934 B 12 DIN 127 B 13 DIN 9021	2		
2	24.8195.25	Federring	Rondelle Grower	Spring washer		2		
3	24.6486.75	Scheibe	Rondelle	Washer		4		
4	24.56.062	Sperrklinke	Plaque d'arrêt	Lock		2		
5	24.56.063	Distanzring	Entretoise	Spacer		2		
6	21.1442.13	Sechskantschraube	Vis	Screw	M 12x35 DIN 933	2		
7	24.56.812	Rohr vollst.	Tube ens.	Tube assy.		2		
8	24.56.026	Lagerzapfen	Turillon	Pivot		2		
-	24.56.820	Aushebestange vollst. (best. aus den Teilen 9,10 und 11)	Tringle de relevage ens. (compr. les pieces 9,10 et 11)	Lift rod assy. (consisting of parts 9,10 and 11)		2		
9	24.56.028	Stange	Tringle	Rod	M 14 DIN 936 G14x56DIN7152 14x56 ESN 01 17 DIN 125	2		
10	24.1423.27	Sechskantmutter	Ecrou	Nut		2		
11	28.6218.31	Gabelkopf	Fourche	Fork		2		
12	25.9425.36	ES - Bolzen	Axe arrêtoire	Bolt and lock		2		
13	24.6481.31	Scheibe	Rondelle	Washer		4		
14	00.17.002	Ziehspint	Goupille fendue	Splint pin	16h 11x70x62 DIN 1435	7		
15	24.56.824	Aushebearm links vollst.	Bras relevage gauche ens.	Lift arm left assy.		1		
16	25.8424.88	Bolzen	Axe	Bolt		3		
17	24.56.833	Hebel vollst.	Levier ens.	Lever assy.	16h 11x60x51 DIN 1435	2		
18	24.56.825	Aushebearm rechts vollst.	Bras relevage droit ens.	Lift arm right assy.		1		
19	25.8424.87	Bolzen	Axe	Bolt		2		
20	00.15.817	Oberlenker hinten vollst.	Barre de relevage arrière ens.	Upper steering assy.	1			
21	00.15.072	Gelenkauge	Gailet d'articulation	Joint		1		
22	00.15.068	Spannhülse	Ecrou tendeur	Tenter sleeve	1			
23	00.15.070	Gelenkauge	Oeillet d'articulation	Joint	1			

Art.Nr. 0646

Heckaushebung
SUPERIOR 2500Relevage arrière
SUPERIOR 2500Rear lifting
SUPERIOR 2500

EB 1705.00 / 72